

A Robot-vision System for Autonomous Vehicle Navigation with Fuzzy-logic Control using Lab-View

Juan Manuel Ramírez, *IEEE Senior Member*
*Instituto Nacional de Astrofísica,
Óptica y Electrónica*
Coordinación de Electrónica
Tonantzintla, Puebla. C.P. 72000

Pilar Gómez-Gil, *IEEE Senior Member*
*Universidad Popular Autónoma del
Estado de Puebla*
Centro Interdisciplinario de Postgrado
Puebla, México. C.P. 72160

Filiberto López Larios, *M.Sc. student*
Universidad de las Américas, Puebla
Departamento de Computación, Electrónica y Mecatrónica
Cholula, Puebla, México. C.P.72820

Abstract

This paper describes a navigation system for an autonomous vehicle using machine vision techniques applied to real-time captured images of the track, for academic purposes. The experiment consists on the automatic navigation of a control remote car through a closed circuit. Computer vision techniques are used for the sensing of the environment through a wireless camera. The received images are captured into the computer through the acquisition card NI USB-6009, and processed in a system developed under the LabView platform, taking advantage of the toolkit for acquisition and image processing. Fuzzy logic control techniques are incorporated for the intermediate control decisions required during the car navigation. An efficient approach based on logic machine-states is used as an optimal method to implement the changes required by the fuzzy logic control. Results and concluding remarks are presented.

1. Introduction

An autonomous navigation system consists on a self-piloted vehicle that does not require an operator to navigate and accomplish its tasks. The aim of an autonomous vehicle is to have self sufficiency and decision making installed within it. Some of the areas where autonomous vehicle are used are space rovers, rice planting and agricultural vehicles [1,2], autonomous driving for urban areas, security and surveillance [3], and also exploration of any place

where human life may be at risk like a mine or a place with fire hazard. There is a whole variety of autonomous vehicles present, with an extensive classification and categories depending on their characteristics [4,5]. Some of those characteristics described in the literature are: Autonomy level, methods of data acquisition, methods of localizations, goal tasks, displacement techniques, control methods, and so on. The project presented in this paper is restricted to the autonomous navigation of a small control remote car through a closed circuit. Although it is a very specific task in a controlled environment, it is indented to provide a platform for academic purposes, in which several approaches of navigation control can be tried, and different schemes of pre-processing image techniques can be used in educational experiments. The software package Lab View and their available toolboxes on image analysis acquisition and fuzzy logic control [6,7], have been found to be an excellent platform for experimentation purposes for a quick design, implementation, and test of the prototypes. It is expected to continue the experimentation with this prototype in order to explore further tasks, which would require the use of more sophisticated control heuristics such us artificial intelligence and neural networks techniques.

2. Hardware description

The implemented system aims to the wireless control of a small remote control car from a laptop computer. The vehicle is equipped with a wireless

camera which sends in real time the video signal corresponding to the path. Once the streaming data corresponding to the video signal of the path is entered into the computer, it is processed through a Lab View application, which generates the control signals to be applied to the remote control of the vehicle. A block diagram of the system is presented in figure 1. The small pictures are real images of the used hardware which is listed as follows: data acquisition I/O card NI USB-6009, wireless analog mini-camera JMK, Dazzle video capture card, a small digital-remote control car. Due to the limitations on the maximum current provided by the output port of the I/O card, a simple optocouplers-based interfaced was included between the NI card and the remote control as a conditioning signal stage.

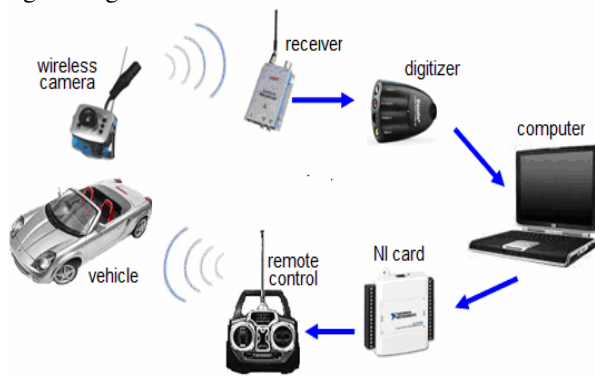

Figure 1. Schematic representation of the system

3. Fuzzy logic control in Lab-view

Fuzzy logic control has been extensively used in many applications including commercial products. There is a large amount of references and books on the topic [8,9], and this paper is not intended to revise again the theory. However, what it is important to point out, is the use of the Lab-view toolbox on fuzzy logic control, which was found an excellent platform to support design, implementation, and test of any system control based on fuzzy logic techniques. This feature in conjunction with the image analysis and acquisition library IMAQ-VISION and Vision Builder from NI, were the key for a quick and accurate implementation of the system described in this paper. There are two types of fuzzy inference systems that can be implemented in the Fuzzy Logic Toolbox: Mamdani-type and Sugeno-type [9]. These two types of inference systems vary in the way outputs are determined. The method used in the control described

in this paper is the Mamdani type, which is the most commonly seen fuzzy inference method, and it is represented in Figure 2. It includes fuzzification of input data based on membership functions, an inference rules database, and defuzzification of the output signal. Mamdani-type inference expects the output membership functions to be fuzzy variables, in consequence, after agregation of signal outputs a defuzzification is needed. The LabView toolbox on fuzzy logic control includes edition of the fuzzy variables and the corresponding triangular and trapezoidal. membership functions, a friendly rulebase editor to enter the if-then rules associated to the fuzzy control, and some defuzzification methods such as centroid, center of maximum, and min-max, which are mathematical operations over a two dimensional function obtained from the combination of the fuzzy outputs. Figure 3 shows the rulebase editor.

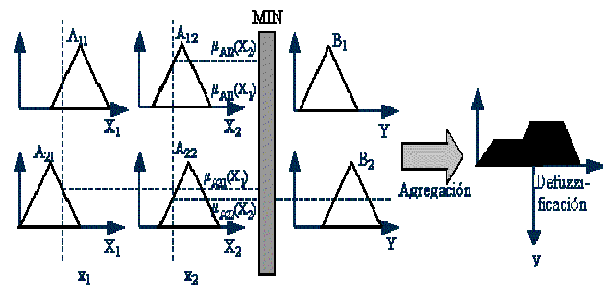

Figure 2. Mamdani type fuzzy inference method

In the project described in this paper, there are two output variables: The steering wheel angle, and the speed. These two signals are connected to the remote control as the guidance mechanism of the vehicle. Each signal allows sixteen values coded in 4 bits. In the case of the speed it covers positive and negative values for movements in reverse, and in the case of the steering wheel angle it covers an angle range of $\pm 45^\circ$. The input information needed to locate the relative position of the vehicle relies on the image sequence detected by the wireless camera, which is a streaming data of 30 images per second. Figure 4 shows a typical image of the scene detected by the vehicle. The program automatically detects and marks the frontal part of the car as the image reference with a yellow box, and the path lines with two red lines. This information is further analyzed in order to make a decision concerned to the car position with respect to the path, and the required action to keep the track in the circuit. The numerical information regarding the

angle of the lines representing the road path, is codified as a fuzzy variable to be used in the control system, as described in the next sections.

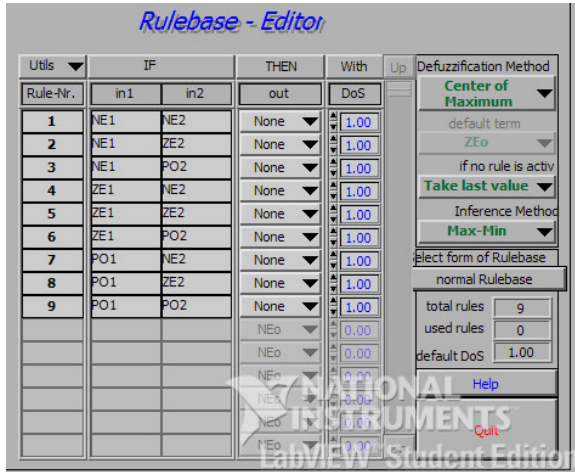

Figure 3. LabView Rulebase editor

4. The Lab View IMAQ vision toolbox

The IMAQ vision is a virtual instruments library aimed to the design and implementation of computer vision and image analysis scientific applications. It includes tools for vision controls using different type of images, image processing operations, like binarization, histograms, filters, morphology operations, and so on. It also provides options for a graphical and numerical image analysis through lines, circles, squares or coordinate systems on the captured image. In addition, National Instruments has developed the so called Vision Builder, which is an interactive software package for configuring and implementing complete machine vision applications using the same graphic philosophy of LabView, with high-level operations like classification or optical character recognition. In the project described in this paper, the image is video-captured, modified from color to gray scale type, and binarized through the corresponding tools. The image of the road is analyzed in order to segment the lines defining the path. Numerical information regarding the relative position of these lines with respect to the reference, which is the center of the car, as well as the angle, is obtained through the analysis of those lines, and is codified as fuzzy variables to be used in the control.

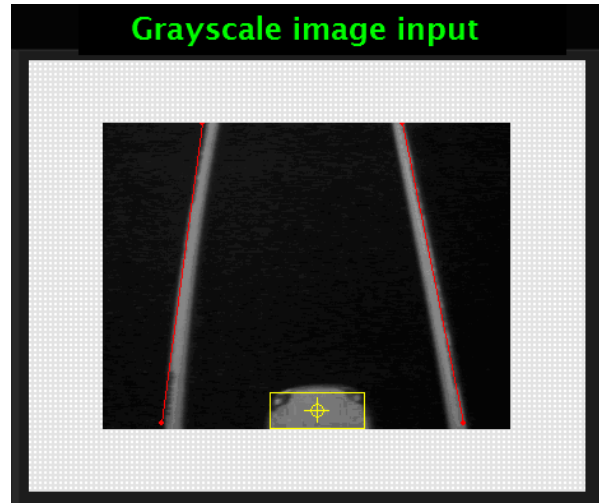

Figure 4. Image of the road looked from the camera

5. Programming approach

The control program developed in LabView was programmed following an approach of machine states logic design. According to the scene detected the vehicle could be located in one of six states as described in the state diagram of figure 5.

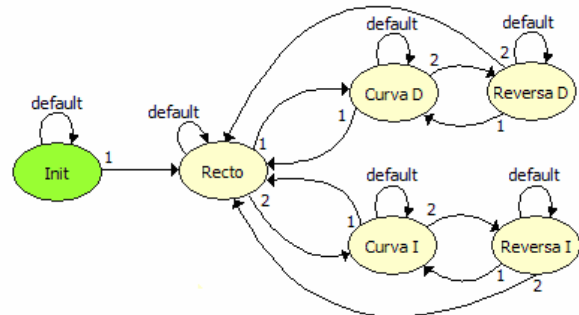

Figure 5. Machine states diagram for the control flow of the vehicle

Figure 6 shows the code in the Lab View graphical language corresponding to the state “curve to the right” called “*Curva D*”. The internal routines included in each state are basically the same with small differences according to the corresponding position, so for the purposes of this paper only the state “*curva D*” will be explained.

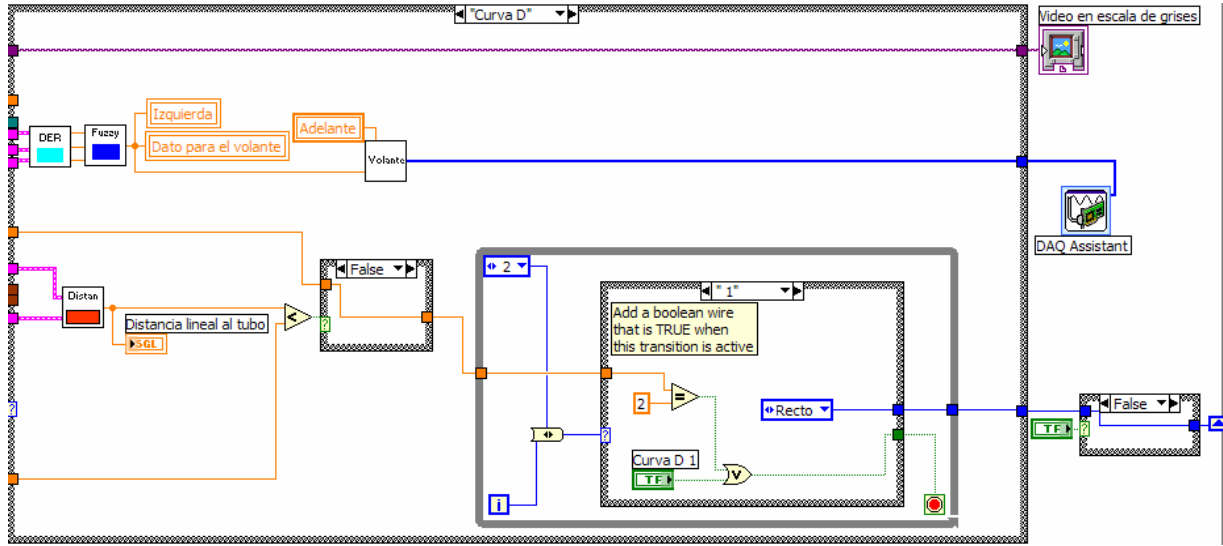

Figure 6. Graphical code corresponding to the state “Curva D”

Inside the main block in Figure 6, we can distinguish a sub-virtual instrument called DER which has the action of obtaining the numerical representation derived from the visual information of the road. Figure 7 corresponds to the code used to

derive two values named as “maximo” and “minimo” with respect to the center of the vehicle, from the right and left lines obtained from the input image of the road.

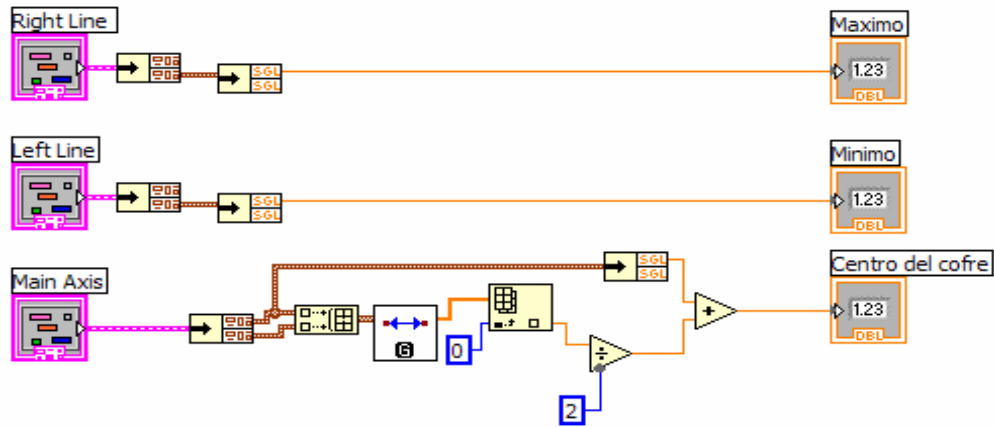

Figure 7. Sub-virtual instrument “fuzzy”

The obtained values max, min, and center, are entered to the next stage, which applies the fuzzy logic rules to obtain the required output value used to control the steering wheel angle, and the displacement of the vehicle, in consequence. The output value is

converted to the 4 bit digital word required in the remote control through a table containing the corresponding codes, as shown in Figure 8. Once all the operations are completed, the process starts again in a new state depending on the position of the vehicle.

When the button “stop” in the main display is pressed, the program goes to the state “init”, where the

program waits until the user decides to resume the car movement or to finish the process.

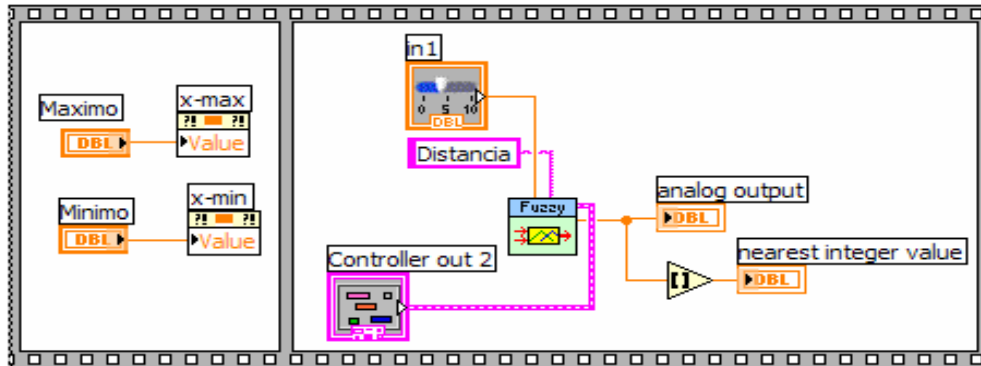

Figure 8. Block code to obtain the steering angle code from the “maximo” and “minimo” values

6. Results

Figures 9, 10 show the frontal panel of the program in two cases. The frontal panel consists on the buttons start-stop, the current machine state, the visual indicators for the speed and the steering wheel angle, and a window to show the scene visualized from the car in real time. When the button “start” is pressed it changes to green color, the machine state changes to “recto”, and the vehicle starts moving. Figure 9 present two cases: The first one corresponds to the initial state once the system is turned on. The second one shows the case in which the vehicle detects a curve to the right and the steering wheel is forced to do the turn.

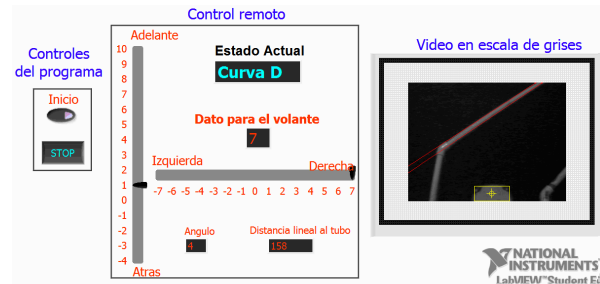

Figure 10. Control panel in the state “Curva D” (curve to the right)

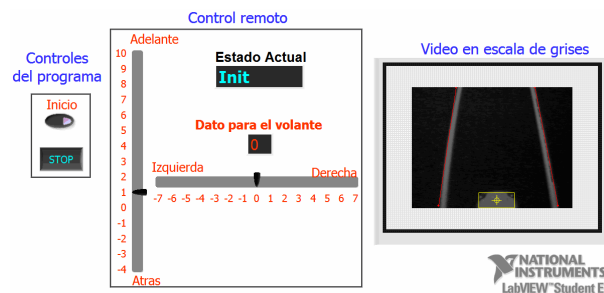

Figure 9. Control panel in the state “Init”

A simple experiment aimed to test the response of the vehicle was implemented. The car was located in a linear track of 4 meters, with an initial position of 70 pixels or 10 cm. out of the center. The car was expected to correct its position until the center is reached. The experiment was carried out several times. After averaging the trajectories, the curve shown in figure 11 was obtained. It can be seen that the vehicle stabilizes after some oscillations in approximately 1.5 meters. Additional experiments and results can be checked at the document in reference [10].

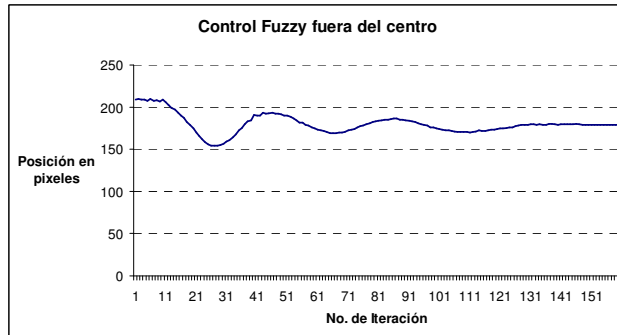

Figure 11. Vehicle oscillations in a straight line

7. Conclusions

An autonomous vehicle navigation system, based on fuzzy logic control techniques with robot vision capabilities has been presented. This experiment was designed with academic purposes on a LabView platform, taking advantages of the toolbox on fuzzy logic control acquisition library IMAQ-VISION. These resources were found an excellent tool to develop in short time with a very good flexibility and excellent performance, the design, implementation and test of a control system such as the one described in this paper. This prototype is ready to support further experimentation in different tasks, including different heuristics of control with the use of artificial intelligence techniques in different environments. It is also worth to point out that a rigid camera like the one used in this project is a considerable limitation. The use of a more sophisticated camera with options like pan, tilt, or zoom, could be a very good improvement, for the possibility to anticipate possible trajectories and do a movement strategy in advance, but of course, with an increasing in the cost of the prototype.

8. References

- [1] Yoshisada Nagasaka, Naonobu Umeda, Yutuka Kanetia, Ken Taniwaki, and Yahsuro Sasaki, "Autonomous guidance for rice transplanting using global positioning and gyroscopes", *Computers and Electronics in Agriculture*, vol. 43, issue 3, pp 223-234, 2004.
- [2] J.N. Wilson, "Guidance of agricultural vehicle – a historical perspective", *Computers and Electronics in Agriculture*, vol. 25, issue 1-2, pp 3-9, 2003
- [3] Nicholas N. Flan, Kevin L. Moore, "A small mobile robot for security and inspection", *Control Engineering Practice*, vol. 10, issue 11, pp 1265- 1270, 2004
- [4] Massimo Alberto Alessandra, "Vision-based intelligent vehicle: state of the art and perspectives", *Robotics and Automation Systems*, vol. 32, issue 1, pp. 1-16, 2000.
- [5] Ade la Escalera, M. Mata, "Traffic sign recognition and analysis for intelligent vehicle", *Image and Vision Computing*, vol. 21, issue 3, pp. 247-258, 2003.
- [6] NI Vision Builder for Automated Inspection. Application Notes, National Instruments, 2003.
- [7] NI Fuzzy Logic Control Toolbox. Application Notes, National Instruments, 2002.
- [8] Kevin M. Passino, Stephan Yurkovich, *Fuzzy Control*. Addison Wesley Publishing Co, 1st ed. 1997.
- [9] Clarence W. Desilva, *Intelligent Control: Fuzzy Logic Applications*, CRC, 1995.
- [10] Filiberto López Larios, "Navegación de un vehículo guiado por tratamiento y análisis de imágenes con control difuso", Tesis de Maestría, Universidad de las Américas, Puebla, 2007.
- [11] Jang, J.-S. R. and C.-T. Sun, *Neuro-Fuzzy and Soft Computing: A Computational Approach to Learning and Machine Intelligence*, Prentice Hall, 1997